

(□可选项)  
attached parts: nut&washer  
M7x0.75

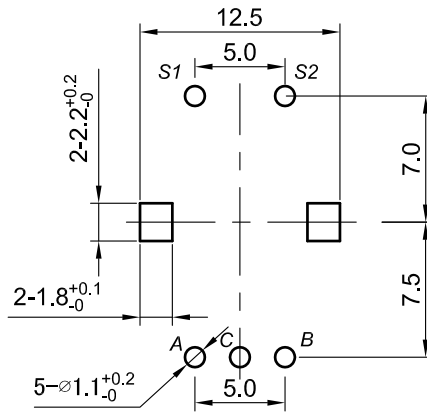

P.C.B. mounting hole detail

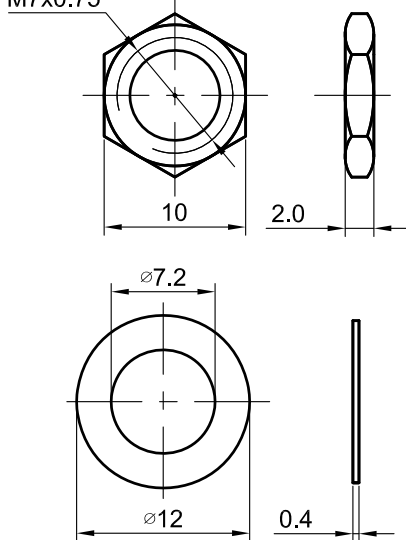
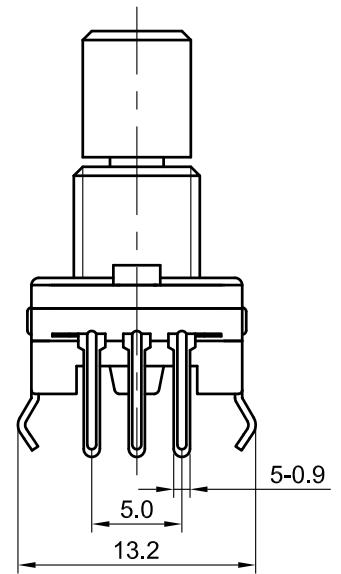

X	L	F
20F10	20	10
15F7	15	7.0
15F6	15	6.0
13F4	13	4.0
10F4	10	4.0
15.5F5	15.5	5.0
20F12	20	12
17.5F7.5	17.5	7.5
28F7	28	7.0
25F7	25	7.0
15F4.5	15	4.5
17F7	17	7.0

X	L	F
19F7	19	7.0
25F12.5	25	12.5
21F10	21	10
15F5	15	5
13F5	13	5
20F7	20	7

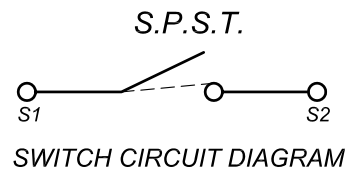

Pulse type

Y	C. C	PULSE
20C20P	20	20
30C15P	30	15

1.一般事项General

1.1适用规格Scope

本规格适用于微小电流回路的电子设备,属11型回转编码器.

This specification applies to 11mm size low-profile rotary encoder(incremental type) for microscopic current circuits,used in electronic equipment

1.2标准状态Standard atmospheric conditions

除另外有规定外,测量应在以上状态下进行:

Unless otherwise specified,the standard range of atmospheric conditions for making measurements and test is as following limits:

温度Ambient temperature: 15°C to 35°C

相对湿度Relative humidity : 25% to 85%

气压Air pressure : 86kpa to 106kpa

1.3使用温度范围

Operating temperature range: -10°C to 70°C

1.4保存温度范围

Storage temperature range : -40°C to +85°C

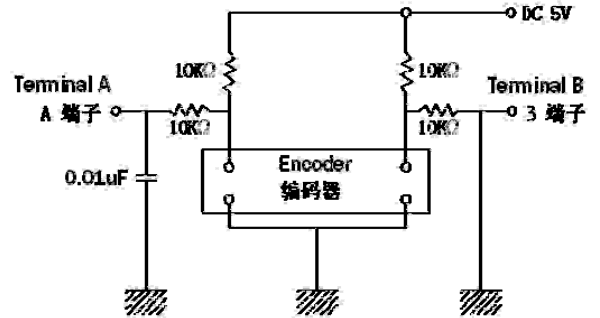

FIG1 《图1》

2.构造Construction

2.1尺寸Dimensions

见所附成品图Refer to attached drawing

3.额定值Rating

3.1额定电压

Rated voltage: DC 5V

3.2最大额定电流(阻抗负载)

Maximum operating current (resistive load)

各相导线 Each lead: 0.5mA(MAX 5mA; MIN 0.5mA)

公共导线Common lead:1mA(MAX 10mA; MIN 0.5mA)

4.Application Nots 使用上的事项

4.1避免储藏于高温、潮湿及腐蚀的场所,产品购入后尽可能在6个月内使用完.拆包装后未使用完的剩余产品需储存于防潮的环境下.

Avoid storing the products in a place at high temperature,high humidity and in Corrosive gases.Please use this product as soon as possible with 6 months limitation.If any rimainder left after packing is opened,please store it with proper moistureproofing,gasproofing etc.

4.2编码器信号的计算方法应将操作的速度,信号的取样时间及电子回路中的微电脑软体等考虑进去

The encoder pulses count method should be designed with taking operating speed,sampling time and design of the microcomputer softwae into cosideration.

4.3此产品在定位点的输出阻抗波形参照(5-1),因此在设计软体时请留意其状态.

With this products the detent position output consnlt fig.5-1.Therefore make the A phase the reference at the soft ware design stage.

4.4在设计时要考虑到杂讯,建议使用C/R滤波电路(图1).

At design of the pulse count process.Using the C/R filter circuit is Recommended.(fig.1)

4.5本产品请勿碰触到水,可能会导致输出波形的异常.

Care must be taken not to expose this product to water or dew to prevent possible problem in pluses output waveform

5.电气性能 ELECTRICAL CHARACTERISTICS

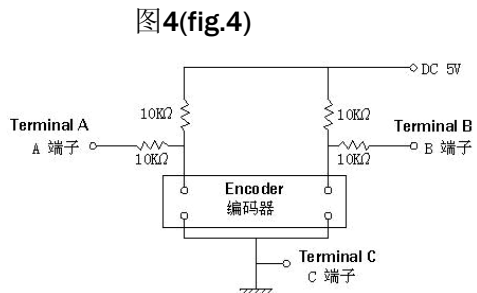
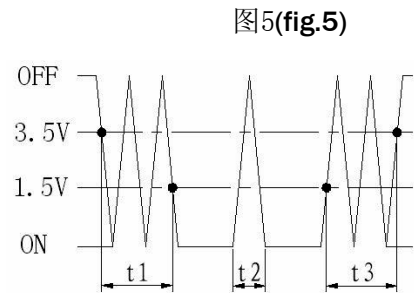
项目 ITEM	条件 CONDITIONS	规格 SPECIFICATIONS	
<b>5.1 输出信号</b> <b>Output signal format</b>	<b>A、B两信号输出相位差,输出波形说细见(图2/3)(虚线表示带卡点位置的上攀子处位置)</b> <b>2 phase different signals(signal A,signal B)Details shown in(fig.2/3)</b> <b>(the broken line shows detent position.)</b>		
	轴回转方向 <b>Shaft rotational direction</b>	信号 <b>Signal</b>	输出波形 <b>Output</b> 图2 fig.2                      图3 fig.3
	顺时针方向 C. W	A(A-C端子间) <b>A(Terminal A-C)</b> B(B-C端子间) <b>B(Terminal B-C)</b>	
	逆时针方向 C. C. W	A(A-C端子间) <b>A(Terminal A-C)</b> B(B-C端子间) <b>B(Terminal B-C)</b>	
<b>5.2 分解能力</b> <b>Resolution</b>	回转 <b>360°</b> 的输出脉冲数. <b>Number of pulses in 360° rotation.</b>	<input type="checkbox"/> 15个脉冲/360° (图2) <b>15Pulsrs/360° fig2 for each phase</b> <input checked="" type="checkbox"/> 20个脉冲/360°(图3) <b>20Pulsrs/360° fig2 for each phase</b>	
<b>5.3 开关特性</b> <b>Switching characteristics</b>	下(图4)所示回路,轴以 <b>360°/sec</b> 的速度转动测定. <b>Measurement shall be made under the condition as follows.</b> <b>Shaft rotational speed:360°/S Test circuit:(fig.4)</b>  (注)编码 <b>OFF</b> 指输出电压 <b>3.5V</b> 以上的状态(fig.5).Code-OFF area:The area which the voltage is 3.5V or more(fig.5) 编码 <b>ON</b> 指输出电压 <b>1.5V</b> 以下的状态(fig.5).Code-ON area:The area which the voltage is 1.5V or less(fig.5)		
<b>5.3.1 振荡</b> <b>Chattering</b>	编码 <b>OFF</b> → <b>ON</b> 或 <b>ON</b> → <b>OFF</b> 时,输出 <b>1.5~3.5V</b> 通过时间应符合规定. <b>Specified by the signal's passage time from 1.5V to 3.5V of each switching position(code OFF~ON or ON~OFF)</b>	<b>t1,t3 ≤ 5ms</b>	
<b>5.3.2 滑动杂音</b> <b>(突跳)</b> <b>Sliding noise</b> <b>(Bounce)</b>	编码 <b>ON</b> 部分的 <b>1.5V</b> 以上的电压变动时间在振荡 <b>t1,t3</b> 之间会产生 <b>1ms</b> 以上, <b>1.5V</b> 以下的 <b>ON</b> 部分另外,如果各突跳间 <b>1.5V</b> 以下的范围在 <b>1ms</b> 以上时,则判定为另一个突跳. <b>Specified by the time of voltage change exceed 1.5V in code-ON area. when the bounce has code-ON tie less than 1ms between chattering (t1 or t3).the voltage change shall be regarded as a part of chattering. when the code-ON time between 2 bounces is less than 1ms.they are regarded as 1 linded bounce.</b>	<b>t2 ≤ 3ms</b>	

**EC11 SERIES SPECIFICATION EC11系列规格书**

5.电气性能 ELECTRICAL CHARACTERISTICS		
项目 ITEM	条件 CONDITIONS	规格 SPECIFICATIONS
5.3.3滑动噪音 Sliding noise	编码OFF部份的电压变动. The voltage change in code-OFF area.	3.5V以上 3.5V min
5.4相位差 Phase difference	<p>下(图6)所示回路,轴以360° /sec的速度转动测定. Measurement shall be made under the condition which the shaft is rotated at 60r/min</p> <p align="center">图6 fig.6</p> <p>A信号(A C)间 signal A B信号(B C)间 signal B</p> <p align="center">T1 T2 T3 T4</p> <p align="center">C.W Direction</p>	T1、T2、T3、T4 ≥ 4ms 见图6(fig.6)
5.5绝缘阻抗 Insulation resistance	在端子和轴间施加电压250V DC. Measurement shall be made under the condition which a voltage of 250V DC is applied between individual terminals and bushing.	100M Ω 以上 100M Ω Min
5.6耐电压 Dielectric strength	在端子和轴间施加AC 300V电压1分钟 A voltage of 300V AC shall be applied for 1 minute between individual terminals and bushing	不得有绝缘破坏 Without arcing or breakdown
5.7端子间接触阻抗 Contact resistance	编码讯号处于ON时安定状态条件下测定. Measurement shall be made under condition which a output signal is ON.	1 Ω 以下 1 Ω Max
6.机械性能 Mechanical characteristics		
6.1全回转角度 Total rotational angle		360°(无止档点) 360°(Endless)
6.2定位点力矩 Detent torque	只适用于附卡点装置 Only suitable for C.C, equipment.	3~20mN.m(30~200gf.cm) Shaft rotatable at -10℃ +5℃ 但在-10℃ +5℃轴勉强可转动
6.3定位点数及位置 Number of detent and position	只适用于附卡点装置 Only suitable for C.C, equipment.	30detents(Step angle:12° ±2°) □30点定位(间隔角度12° ±2°)
		20detents(Step angle:18° ±2°) ■20点定位(间隔角度18° ±2°)
6.4轴的推拉强度 Push-pull strength of shaft	在轴端,沿轴向施加8Kg的静负荷推和拉各10秒钟 (产品焊锡固定在PCB上). Push and pull static load of 8Kg shall be applied to be shaft in the axial direction for 10s. (After soldering of the PC board)	轴无破损,回转无异常,电气性能无异常 Without damage or excessive play in shaft. NO excessive abnormality in rotational feeling. And electrical characteristics and be satisfied.
6.5轴摆动 Shaft wobble	在轴前端5mm处,沿径向瞬间施加50mN.m(500gf.cm)的力. A momentary load of 50mN.m(500gf.cm) shall be applied at the point 5mm from the tip of the shaft in a direction perpendicular to the axis of shaft.	0.7xL/30mm p-p以下(L:指安装平面到轴的柄端的距离) 0.7xL/30mm p-p Max或(L:Distance between mounting surface and measuring point on the shaft)

**EC11 SERIES SPECIFICATION EC11系列规格书**

<b>6.机械性能 Mechanical characteristics</b>		
<b>项目 ITEM</b>	<b>条件 CONDITIONS</b>	<b>规格 SPECIFICATIONS</b>
<b>6.6</b> 轴的回转方向摆动 <b>Shaft play in rotational wobble</b>	用角度板测定。 <b>Testing by angle board.</b>	<b>5° 以下</b> <b>5° MAX</b>
<b>7.耐久性能 Endurance characteristics</b>		
<b>7.1</b> 回转寿命 <b>Rotational life</b>	在无负荷条件下轴以 <b>600</b> 周/小时速度回转 <b>30000</b> 周。 <b>The shaft of encoder shall be rotated to 30000 cycles at a speed of 600cycles/H without electrical load,after with easurements shall be made.</b>	端子间接触阻抗 <b>200 Ω</b> 以下。 <b>Contact resistance 200 Ω MAX.</b> 尚余有轻微定位感 <b>Vibration t1,t3≤5mS 振荡 t1,t3≤5mS</b> <b>Bounce t2≤5mS 突跳 t2≤5mS Detent feeling has to remains</b>
<b>7.2</b> 耐湿性 <b>Damp heat</b>	温度 <b>40±2℃</b> ,湿度 <b>90~95%</b> 的恒温恒湿槽中放置 <b>48</b> 小时后,在常温、常湿中放置 <b>1.5</b> 小时后测试。 <b>The encoder shall be stored at temperature of 40±2℃ with relative humidity of 90% to 95% for 48H in a thermostatic chaber.And the encoder shall be subjected to standard atmospheric conitions for 1.5H After which measurements shall be made.</b>	所有项应满足初期规格 <b>Specifications in clause all items is shall be satisfied.</b>
<b>7.3</b> 耐热性 <b>Dry heat</b>	温度 <b>80±3℃</b> 的恒温箱中放置 <b>48</b> 小时,然后在常温、常湿放置 <b>1.5</b> 小时后测试。 <b>The encoder shall be stored at temperature of 80±3℃ for 48H in a thermostatic chamber.And the encoder shall be subjected to standard atmospheric condetions for 1.5H,After which measurements shall be made</b>	所有项应满足初期规格 <b>Specifications in clause all items is shall be satisfied.</b>
<b>7.4</b> 低温特性 <b>Cold</b>	温度 <b>-25℃±3℃</b> 的恒温箱中放置 <b>48</b> 小时,常温、常湿放置 <b>1.5</b> 小时后测试。 <b>The encoder shall be stored at temperature of -25℃±3℃ for 48H in a thermostatic chamber.And the encoder shall be subjected to standard atmospheric condetions for 1.5H,After which measurements shall be made</b>	所有项应满足初期规格 <b>Specifications in clause all items is shall be satisfied.</b>
<b>7.5</b> 焊锡性 <b>Solder ability</b>	端子在 <b>235℃±5℃</b> 温度的焊锡槽内浸锡 <b>3±0.3</b> 秒。 <b>The terminals shall be imersed into solder bath at 235℃ for 3±0.3s in the same manner as para.</b>	浸锡面积须有 <b>75%</b> 以上焊锡附着 <b>A new uniform coating of solder shall cover 75% minimum of the surface being immersed.</b>
<b>7.6</b> 耐焊接热 <b>Resistance to Soldering heat</b>	手工焊接 <b>Manual soldering</b> 温度 <b>300℃</b> 以下,时间 <b>3</b> 秒以内。 <b>Bit temperature of soldering iron:300℃ less than application time of slodering iron:within 3s</b> 槽焊 <b>Dip soldering</b> 使用基板:T=1.6mm的单面覆铜板。 <b>Printed wiring board:single-stded copper clad laminate board with thickness of 1.6mm.</b>	不得有绝缘体的破坏、变形、接触无异常。 <b>Electrical characteristics shall be satisfied</b> <b>No mechanical abnormality</b>

**EC11 SERIES SPECIFICATION EC11系列规格书**

7.耐久性能 Endurance characteristics		
项目 ITEM	条件 CONDITIONS	规格 SPECIFICATIONS
7.6耐焊接热 Resistance to Soldering heat	预热:基板表面温度 <b>100℃</b> 以下,时间 <b>1</b> 分钟以内。 Preheating: 1.Surface teperature of board: <b>100℃</b> or less 2.preheating time:within <b>1</b> min. 焊接:温度 <b>235±5℃</b> 或以下,时间 <b>3</b> 秒以内 Soldering:Soleer tempeature: <b>235±5℃</b> or less Immersion time:within 3s	不得有绝缘体的破坏、变形、接触无异常。 Electrical characteristics shall be satisfied No mechanical abnormality
推动开关部分 <b>Push Switch Portion</b> 备注:以下规格适用于 <b>EC11</b> 编码带开关系列。 No:The following specification is only suitable for the one type with construction of <b>EC11</b> encoder series.		
1.额定值 Rating		
1.1额定电压 Rated voltage: <b>DC 5V</b> 1.2最大额定电流(阻抗负载) Maximum operating current(resistive load): <b>10mA MAX.</b>		
2.电气性能 Electrical Characteristics		
项目 ITEM	条件 CONDITIONS	规格 SPECIFICATIONS
2.1接触电阻 Contact resistance	用 <b>DC 5V 10mA</b> 电压测定 Voltage test at <b>DC 5V 10mA</b> .	<b>100m Ω or less</b> $\leq 100m\Omega$
2.2绝缘阻抗 Insulation resistance	在端子和安装板间施加电压 <b>250V DC</b> . Measurement shall be made under the condition which a voltage of <b>250V DC</b> is applied between individual terminals and bushing and bushing and plank.	<b>100M Ω 以上</b> <b>100M Ω Min</b>
2.3振荡 Bouncing	以 <b>1秒钟1</b> 往返(OFF-ON-OFF)按压动作。 Shaft shall be push at <b>1 cycles/s(OFF-ON-OFF)</b> .	<b>10ms or less</b> $\leq 10ms$
2.4耐电压 Dielectric strength	在端子和安装板间施加 <b>AC300V</b> 电压 <b>1</b> 分钟 A voltage of <b>300V AC</b> shall be applied for <b>1</b> minute between individual terminals and bushing and plank.	不得有绝缘破坏 Without arcing or breakdown
3.机械性能 Mechanical characteristics		
3.1开关电路.接点数 Switch circuit and number of pulse		单极单投(按压ON) Single pole and single throw (PUSH ON)
3.2开关动作力 Operation fore of switch	在轴端,沿轴向施加的按压力。 Push static load to the shaft in the axial direction	<b>400-600gf.cm</b>
3.3开关动移动量 Travel of switch		<b>0.5(+0/-0.30)mm</b>
4.耐久性能 Endurance Characteristics		
按压寿命 push life	The shaft of encoder shall be push to <b>20000</b> cycles at a speed of <b>600</b> cycles/H without electrical load,after with measurements shall be made 在无负荷条件下轴以 <b>600</b> 次/小时速度按压往返 <b>20000</b> 周。	接触电阻: $\leq 200m \Omega$ 其它应满足初期规格。 Contact resistance: <b>200m Ω or less</b> Specifi cation in clause shall be satisfied